

aerl



INSTALLATION AND OPERATION MANUAL

LiFe² 5120S

www.aerl.com.au

TABLE OF CONTENT



1: Introduction	3
2: Glossary	3
3: Safety	3
3.1. Warnings and Cautions	4
3.2. Transportation	4
3.3. Handling	4
3.4. Storage	4
3.5. Long Term Storage Check	5
3.6. Leaking Batteries	5
3.7. Fire	5
3.8. Wet Battery	5
4: Product Information	6
4.1. Introduction: LiFe ² 5120S Battery System	6
4.2. LiFe ² 5120S Battery Module & Box Contents	6
4.3. LiFe ² 5120S Battery Module Interface and Status LEDs	7
4.4. LiFe ² 5120S Battery Module Specifications	8
4.5. LiFe ² 5120S Cabinet Specifications	9
5: Installation	10
5.1. Installation Location and Environment	10
5.2. Battery Cabinets	10
5.3. Battery Connections	11
5.4. Tools	11
5.5. Extra Accessories	11

5.6. Positioning The Cabinet	12
5.6.1. Minimum Cabinet Clearances	12
5.7. Connecting Power Cables and Deploying the Support Feet	12
5.8. Inserting and Fastening Battery Modules	13
5.9. Cable Connection	13
5.9.1. Connecting the Communications and Protective Earth	13
5.10. Connecting to Inverter	14
5.11. Self-Managed Mode (No Comms)	15
5.12. Connecting Multiple Cabinets	15
5.12.1. Connecting Communication Cables Between Multiple Cabinets	15
5.12.2. Connecting Parallel Cabinets to The Inverter	16

6: Commissioning	17
6.1. LED Status	17
6.2. Circuit Breaker Protection	17
6.3. System Start-Up and Shut-Down Procedure	17
6.4. Charging and Discharging	18
6.4.1. Initial System Charging	19
6.4.2. Maintaining Accurate SOC in Self-Managed Application	19

7: Maintenance	19
-----------------------	-----------

8: Adding Batteries to an Existing System	20
--	-----------

9: Recovering a Flat Battery	20
-------------------------------------	-----------

10: Battery End of Life and Recycling	20
--	-----------

11: Battery Cycle Performance Characteristics	21
--	-----------

12: Managed Battery Performance, Charge and Discharge	22
--	-----------

1: Introduction

Introducing the LiFe² 5120S, an advanced Lithium Iron Phosphate (LFP) battery storage system designed for performance and reliability. Featuring sophisticated cell balancing and dual operating modes (Managed and Self-managed), it's optimised for demanding off-grid applications. With a substantial 5.12 kWh capacity and a compact 19-inch rack-mount design, it integrates seamlessly into standard 19-inch server racks or our dedicated pre-wired battery cabinets.

Expand your energy storage capacity effortlessly by connecting up to 64 LiFe² 5120S units in parallel, achieving a maximum system capacity of 327.68 kWh. When paired with integrated inverters, the battery utilises CANBUS communication for precise management in Managed mode, with automatic fallback to Self-Managed mode if communication with the inverter is lost. For enhanced compatibility, the LiFe² 5120S can also function exclusively in self-managed mode without communications with assorted third-party power conversion equipment (PCE), hybrid inverters, battery chargers, and MPPT solar charge controllers.

Engineered for reliability, the LiFe² 5120S supports hot-swapping and incorporates an integrated circuit breaker for safe isolation. The built-in Battery Management System (BMS) monitors the circuit breaker status and can trigger an electronic trip for added protection, complementing the mechanical overcurrent safeguards.

Utilising advanced LFP technology, the LiFe² 5120S delivers exceptional performance with the ability to discharge at temperatures as low as -20°C and charge at temperatures down to -10°C, making it well-suited for operation in a broad range of climate conditions.

This manual provides detailed instructions for the installation and operation of the LiFe² 5120S battery.

2: Glossary

■ BESS Battery Energy Storage System	■ LFP Lithium Ferro Phosphate (LiFePO ₄)	■ DOD Depth of Discharge
■ BMS Battery Management System	■ SOC State of Charge	
■ LED Light Emitting Diode	■ SOH State of Health	

3: Safety

When installing, commissioning, operating, and maintaining the product, strictly adhere to the safety requirements outlined in the manual. Incorrect operation or handling can result in damage to the product and other property, or cause injury or death to the operator or third parties.

When securing the product with screws or other components, use the appropriate tools and apply the torque specified in the manual or on the product label. Failure to do so may result in instability or damage to the product.

Ensure you are familiar with the proper use of different tools beforehand to prevent injury during installation.

Please read this manual thoroughly before installation to ensure the proper and safe installation and use of the product.

3.1. Warnings and Cautions

1. Installers and users must familiarize themselves with this manual.
2. Be cautious when handling power cables and plugs, as they carry voltage from the battery.
3. Ensure a fire extinguisher is readily available before installation and use.
4. Installation and operation must be performed by a suitably qualified person, and the system should be installed in restricted access areas.
5. Due to the weight of the battery module, it is recommended that at least a two-person lift, using lifting tools if necessary.
6. The battery should not be installed in direct sunlight.
7. The battery should not exceed temperatures as indicated in the product datasheet.
8. If the battery has been dropped, punctured, or is wet, do not install or operate the battery.
9. The battery should be kept out of reach of children and animals to prevent injury from accidental contact.
10. The battery should be kept dry and away from water.

3.2. Transportation

AERL LiFe₂ 5120S batteries should be shipped with terminals covered to prevent contact with metal objects and short circuits during transport. To comply with international transport regulations, the batteries are discharged to a specific low SOC before shipping.

Whenever possible, ship batteries in the manufacturer's original packaging, secured horizontally and firmly fastened to a pallet. Avoid shipping batteries vertically, and limit stacking to no more than six batteries.

Store batteries out of the reach of children and animals to prevent injury from accidental contact.

3.3. Handling

- Batteries are heavy and should be handled and installed by an adequate number of personnel using the proper tools.
- Installers should exercise caution during installation to prevent damage to the battery. If the battery is damaged before installation, such as case damage or terminal port damage, do not install or operate it and contact your place of purchase or AERL after-sales support.
- Do not touch the DC bus or battery ports directly.
- Avoid subjecting the battery to external forces, such as dropping it, dragging it on the ground, or placing heavy objects on it.
- Do not clean the battery or allow foreign objects or liquids to enter it.
- Do not unplug any cables while the battery is in operation.
- Do not use the battery with other brands or types of batteries.

3.4. Storage

- Batteries should be stored horizontally.
- Do not store the battery in direct sunlight or high humidity and keep away from heat and water.
- For long-term storage, maintain an ambient temperature of around 25°C.
- For short-term storage, ensure the temperature is between 0°C and 35°C.

3.5. Long Term Storage Check

The battery voltage of LiFe² 5120S batteries should be checked if they have been stored for long periods of time (≥6 months):

1. If the battery voltage is higher than 51.6V, the battery is in good condition and does not need charging. Subsequently, the batteries should be checked every 3 months.
2. If the battery voltage is lower than 51.6V, the battery should be charged to prevent irreversible damage from low SOC. It is recommended to charge the battery with a 55V DC charging voltage and 10A constant current for a minimum of 30 minutes.

3.6. Leaking Batteries

Immediately stop using a damaged battery and dispose of it safely or return it to the manufacturer. Battery damage can lead to electrolyte leakage, which may cause breathing difficulties, skin irritation, and chemical burns. Follow these guidelines promptly if any of the following conditions occur:

- **Eye Contact:** Rinse gently with running water for at least 15 minutes and seek medical help promptly.
- **Skin Contact:** Rinse under running water for more than 15 minutes, remove any contaminated clothing, and seek medical attention.
- **Inhalation or Ingestion:** Leave the contaminated area and seek medical assistance immediately.

3.7. Fire

A battery fire may occur if the battery is too close to a flame or if the environmental temperature is unusually high. If the battery catches fire, it may release carbon monoxide, carbon dioxide, and other gases, emitting smoke.

In case of fire:

- Evacuate the area promptly and call emergency services.
- Use a full-face self-contained breathing apparatus (SCBA) and full protective gear while fighting the fire.
- Use a dry chemical fire extinguisher to cool and extinguish the battery to prevent the fire from spreading.

3.8. Wet Battery

If the battery is submerged in water, stop using it immediately and seek assistance from AERL. If you need to disconnect power or are in the same liquid environment as the battery, wear rubber gloves and boots beforehand to protect from electric shock.

4: Product Information

4.1. Introduction: LiFe² 5120S Battery System

The LiFe² 5120S is an advanced energy storage system. It features an integrated Battery Management System (BMS) that continuously monitors the battery's status and provides comprehensive protection against potentially harmful conditions.

The BMS offers the following protective functions:

- Overcharge and over-discharge protection
- High and low temperature protection
- Overcurrent and short circuit protection
- Active cell balancing

To further enhance safety, the LiFe² 5120S incorporates an electronically controlled circuit breaker. This feature allows for rapid isolation of the battery in case of detected faults or unsafe operating conditions, providing an additional layer of protection beyond the BMS functions.

4.2. LiFe² 5120S Battery Module & Box Contents

Each LiFe² 5120S battery comes supplied with all connection cables required to complete the installation into the LiFe² pre-wired battery cabinets.



Box Contents

#	Part	Qty
1	Termination Plug	1
2	Comms Cable	1
3	M6 x 16 Bolt	4

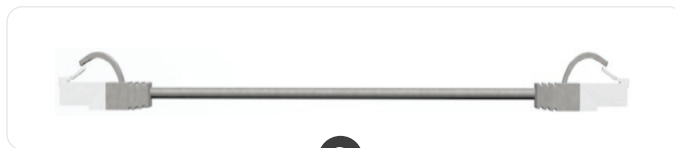

4.3. LiFe² 5120S Battery Module Interface and Status LEDs

LEDs are provided to allow the user and installer to quickly understand the operating state of the battery.



Interface & Status LEDs

There are LEDs on the front panel of LiFe² 5120S that indicate the battery state (Status, Error, and SOC).

Letter	Label	Function
A	COMMS	Inverter Comms
B	OUT	Battery Comms Out
C	IN	Battery Comms In
D	N/A	Error Indication
E	N/A	Battery Status
F	N/A	SOC Indicator
G	ON/OFF	On/Off Switch
H	MCB	Circuit Breaker
I	+	DC+ Port
J	-	DC- Port

4.4. LiFe² 5120S Battery Module Specification

Parameter	Battery Specification
Part Number	LiFe ² 5120S
Nominal Voltage	51.2 V DC
Operation voltage Range	40.8 V DC to 58.4 V DC
Capacity	5.12 kWh / 100 Ah
Depth of Discharge	Up to 100%
Maximum Continuous Discharge Rate	1C (@ 25°C)
Maximum Continuous Discharge Current	100 A (@ 25°C)
Maximum Discharge Power	5.12 kW
Peak Discharge Current	200 A (10.24 kW, 5s)
Maximum Continuous Charge C-Rate	1C (@ 25°C)
Maximum Continuous Charge Current	100 A (@ 25°C)
Peak Charge Current	200 A (@ 25°C)
Integrated Circuit Breaker	1-Pole 125A 80VDC
Lithium Chemistry	LiFePO ₄ / LFP
Cell Construction	Prismatic
Operating Temperature Range Managed	Charge: -10°C to 50°C / Discharge -20°C to 50°C
Operating Temperature Range Self-Managed	Charge: 0°C to 50°C / Discharge -5°C to 50°C
Operating Humidity	Up to 95% (non-condensing)
BMS Over-Voltage Cell Level Protection	3.65 V DC
BMS Under-Voltage Cell Level Protection	2.55 V DC
BMS Over-Temp Cut Off	56°C
Short Circuit Current	4500A
Arc Flash Incident Energy IEm in Cal/cm ² (45cm)	0.341
Arc Flash Incident Energy AFB in cm	23.952
Altitude	< 2500m
DC Connectors	100A Quick Connect
IP Rating	IP20
Efficiency	> 96%
Cooling	Natural Convection
Scalability	64 Batteries in Parallel
Series Connection	Not Permitted
Communications	CAN 2.0A / RS458 / No Comms
Weight	44 kg
Dimensions	440 x 134 x 480 mm
Warranty	5 + 5 Years (up to 10 Years) - Conditions Apply
Certifications - Cell	UL1973, UL9540A, IEC62619:2022, UN38.3
Certifications - Pack	IEC62619:2022, IEC62040, UN38.3, CE
Country of Manufacture	People's Republic of China

4.5. LiFe2-CAB6 & LiFe2-CAB10 Cabinet & Specification

Parameter	Cabinet Specification	
Part Number	LiFe2-CAB6	LiFe2-CAB10
Dimensions (WxDxH)	620 x 600 x 1270 mm	620 X 600 x 1890 mm
Fixing	4 x Wheels & 4 x Feet	
Max. Module Quantity	6 (30.72 kWh)	10 (51.20kWh)
Busbar Continuous Current Rating	600 A	1000 A
Battery Interconnection	Pre-wired Quick Connector with 4 AWG UL Cable	
DC Circuit Breaker	None	None
IP Rating	IP20	
Weight	91kg	128 kg
Warranty	Refer to Warranty Document	



LiFe2-CAB10



LiFe2-CAB6

5: Installation

This section provides crucial information and comprehensive guidelines for installing the LiFe² product range, ensuring a safe and efficient installation process. Proper installation is critical for the system's longevity, efficiency, and safe operation.

5.1. Installation Location and Environment

To ensure safe and long-lasting operation of the LiFe² battery system, it is crucial to choose an appropriate installation location. If you are not using our LiFe² battery cabinets, install the battery in a 19" data rack or another compliant, secure electrical enclosure of your choice. Please note that our IP20 cabinets are designed for indoor use only.

Select an area that meets the following criteria:

1. Easily accessible for connection and maintenance
2. Dry, dust-free indoor environment
3. Free from flammable and explosive materials
4. Ambient temperature between 15-30°C (59-86°F)
5. Relative humidity between 0-95% (non-condensing)
6. Flat, level ground without any inclination or unevenness
7. Clean environment with minimal dust
8. Protected from direct sunlight, rain, or snow
9. Well-ventilated with adequate air circulation
10. Inaccessible to children or pets to prevent accidental injury.
11. Batteries and cabinets should be installed no less than 5 metres from a heat source

5.2. Battery Cabinets

The LiFe² batteries are designed to fit within a 600mm deep 19" equipment rack. AERL offers two pre-wired cabinet options to accommodate 6 and 10 batteries respectively.

These pre-wired cabinets can significantly reduce installation time and are the recommended solution.

If you choose to design and assemble your own battery enclosure, consider the following recommendations:

- Incorporate support rails into your enclosure design where possible.
 - Alternatively, ensure robust securing methods to prevent battery damage,
 - Avoid stacking more than 6 batteries unless the enclosure is specifically engineered to distribute weight evenly.
 - Allow at least 30mm clearance on all sides within the enclosure for adequate air circulation
 - Use power cables of uniform length and size for all connections.
 - Select materials appropriate for the battery's location.
 - Ensure the enclosure meets the required IP (Ingress Protection) rating for the installation environment.:
 - Properly ground the enclosure.
 - Select appropriate fuses, cables, and connections for optimal safety and performance.
-
- Pre-assembled cables must be used when connecting the batteries to a custom made cabinet busbar (or similar). These can be ordered from AERL with Part Number: AERL-BATT-CABLE-2.5.

5.3. Battery Connections

For power cable connections, the LiFe² 5120S uses Exconn (non-keyed) connectors on both positive and negative terminals, streamlining the installation process. When paralleling multiple cabinets, you may need to acquire additional power cables and decide on a method for combining parallel connections. Options include using a DC busbar assembly or a DC combiner box. When selecting power cables, ensure uniform length across all connections to maintain consistent impedance throughout the battery system.

5.4. Tools

The tools below are necessary for the installation of the LiFe² 5120S. Please make sure you are well-prepared before you start your installation.



Utility Knife



Insulated Gloves



Goggles

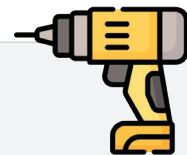

Drill

5.5. Extra Accessories



1. Inverter DC Cabling



2. Cabinet PE Cable



3. Communication Cable

- DC Cables should be sized to suit your connected PCE or load current requirements.
- DC Cable Terminals:
 - LiFe2-CAB6: SCxxx-10
 - LiFe2-CAB10: SCxxx-12
- PE Cable (CSA≥25mm) with Terminal (SC35-6)
- Shielded Communication Cable (CAT5 or higher) (only if connecting to PCE's that Support Managed Communications)

Ensure that you understand your local requirements for battery installations. Installation requirements will differ depending on country and jurisdiction and many may require DC isolation between the battery cabinets and the inverter.

5.6. Positioning The Cabinet

Upon receiving the cabinet, meticulously inspect its exterior and interior for any signs of damage. Should you find any damage, promptly reach out to your supplier for assistance.

The LiFe² cabinets come installed with caster wheels for easy manoeuvrability into position.

5.6.1. Minimum Cabinet Clearances

Minimum Clearance Requirements:

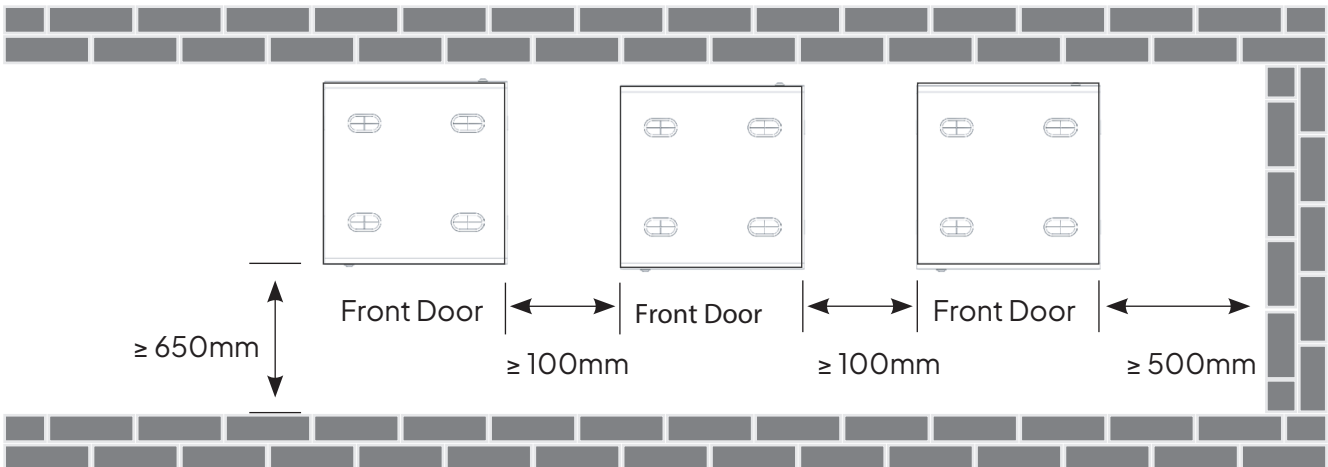

Note: No less than 25mm from the top of cabinet to ceiling when installing indoors.

5.7. Connecting Power Cables and Deploying the Support Feet

After determining the final position, deploy the load-bearing feet of the cabinet. It is crucial to extend these feet fully before installing any batteries to ensure proper weight distribution and stability. To access the main DC cable connection busbar, locate the removable panel on the right side of the cabinet. Remove the internal securing screw and carefully detach the panel to expose the busbar for cable connections.

Ensure all connections are properly torqued and the panel is securely reattached after installation.

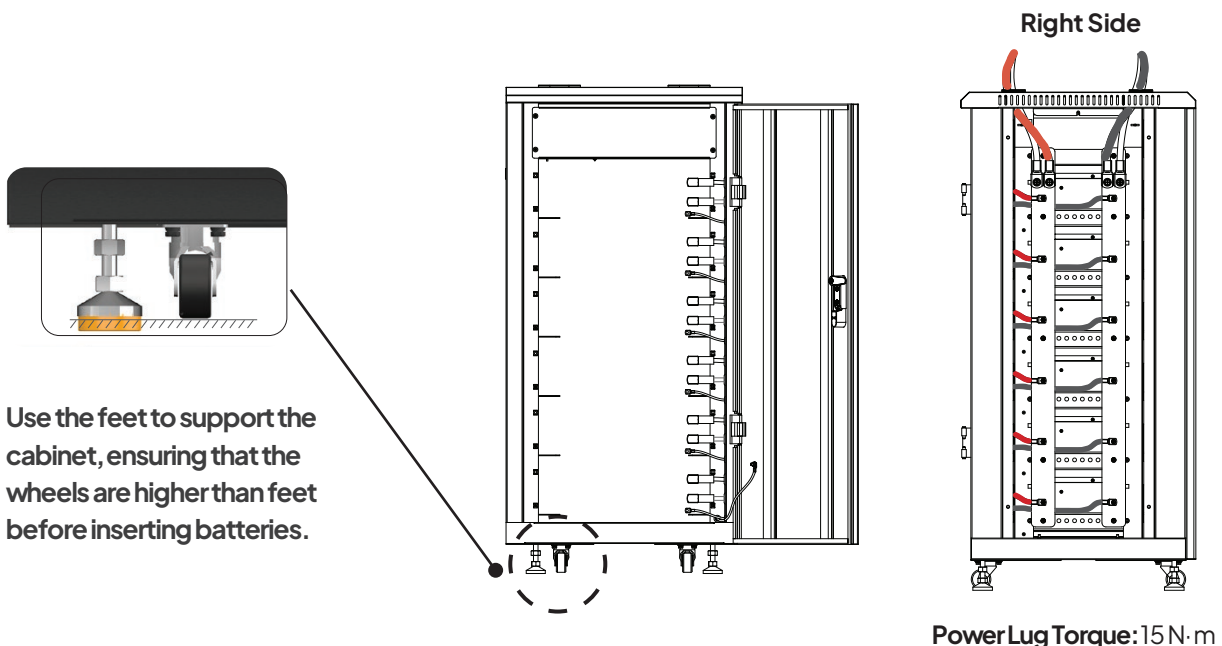

5.8. Inserting and Fastening Battery Modules

The LiFe² 5120S battery modules can be easily installed into the LiFe² battery cabinet. Starting from the bottom of the cabinet, slide the batteries in one by one until the desired amount is installed or the cabinet is full. The batteries should be secured in place using the supplied fastening screws and torqued accordingly.

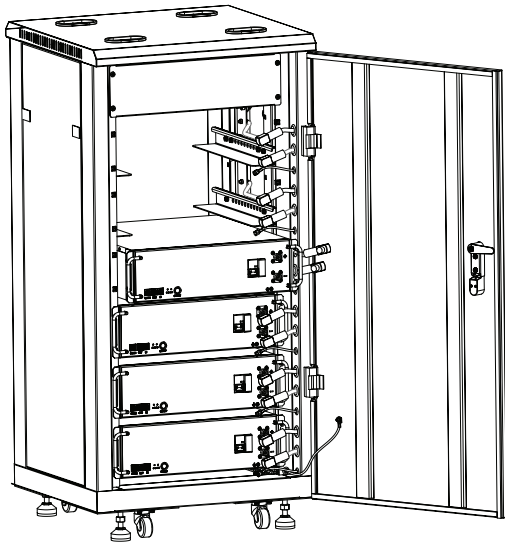

Insert the Modules into the Cabinet

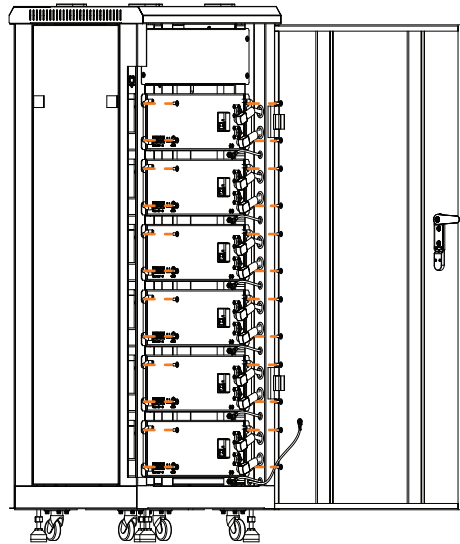

Module Bolt Torque: 3 N·m

5.9. Cable Connection

5.9.1 Connecting the Communications and Protective Earth

Start at the Out Port of the first battery module.
(This battery will be the Master Battery)

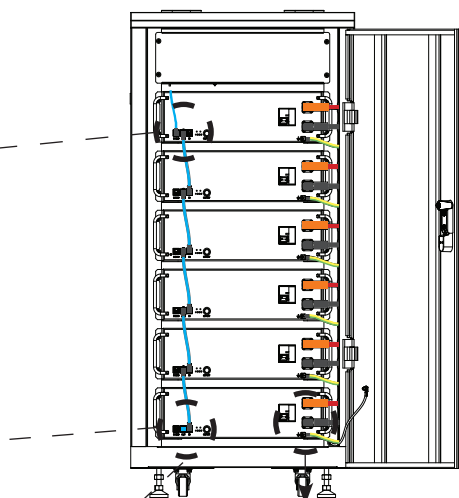
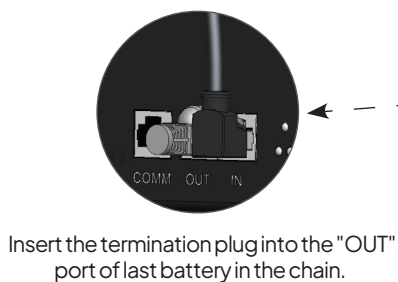
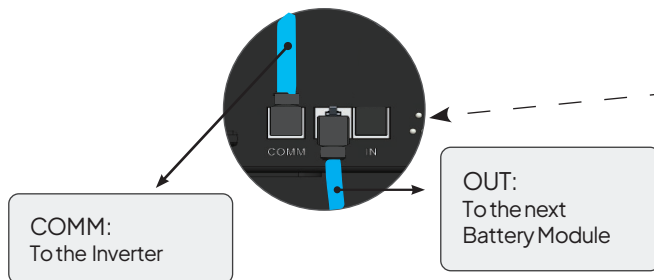

Termination Plug



PE Torque: 3 N·m

Connect the PE to each battery module.

5.10. Connecting to Inverter

Important Note: The LiFe2-5120S comes equipped with a 125A/80 VDC 1-P breaker.

To comply with Australian Standards (AS/NZS 5139), all live battery conductors must pass through 2-P MCCCB's installed between the battery modules and the connected inverter or DC bus.

When connecting the main DC cables to the Positive and Negative of the inverter, ensure you follow the manufacturers guidelines.

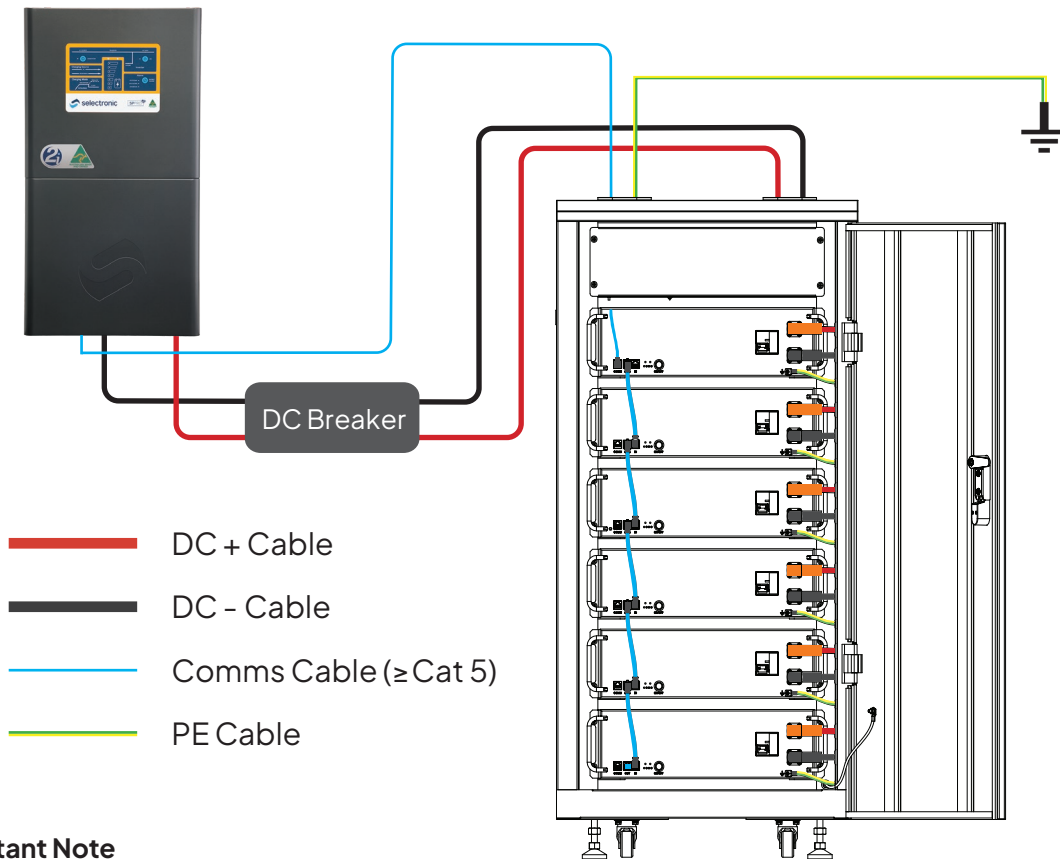

Important Note

- The comms cable should be Cat 5 or greater.

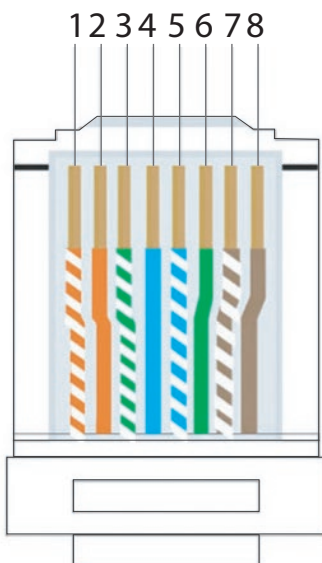

Master Comms Port Pin- Out

PIN No.	Definition
1	NC
2	NC
3	NC
4	CAN_H
5	CAN_L
6	NC
7	RS485B
8	RS485A

5.11. Self-Managed Mode (No Comms)

The LiFe² 5120S can operate without communication in Self-Managed (No Comms) Mode allowing connection to 3rd party charging sources that allow configuration of charging settings. This allows the LiFe² to be used as a lead acid replacement.

By default, the LiFe² battery is configured in Self-Managed Mode.

The battery will automatically switch to Managed (Communication) Mode once the communication cable between the inverter and the master battery is connected.

5.12. Connecting Multiple Cabinets

If a single cabinet does not meet your system storage requirements, then multiple cabinets can be connected in parallel.

5.12.1 Connecting Communication Cables Between Multiple Cabinets

The diagram below shows the way of paralleling multiple cabinets. The communication cable should be connected from the OUT port of the last (bottom) battery of the first cabinet, through the pre-drilled hole in the cabinet to the IN port of the bottom battery of the second cabinet.

Note that the second to third cabinet connection should connect the two top batteries between the cabinets. (the top battery in the second cabinet is connected to the top battery in the third). This process should be repeated copying the same pattern of connection as more cabinets are connected.

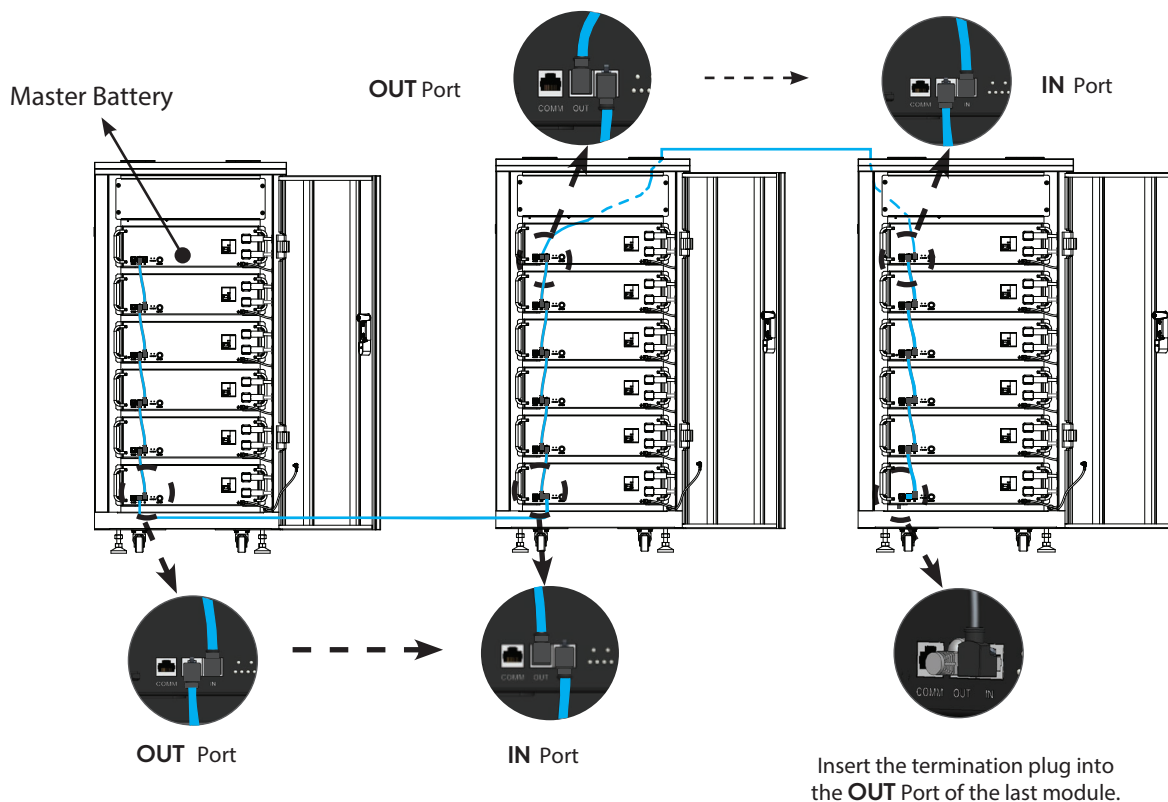

5.12.2 Connecting Parallel Cabinets to The Inverter

STEP
01

Connect the PE cable.

STEP
02

Connect the power cables of the paralleled cabinets to the DC combiner box/DC bus and then to the inverter.

STEP
03

Connect the communication cable between the master battery and the inverter.

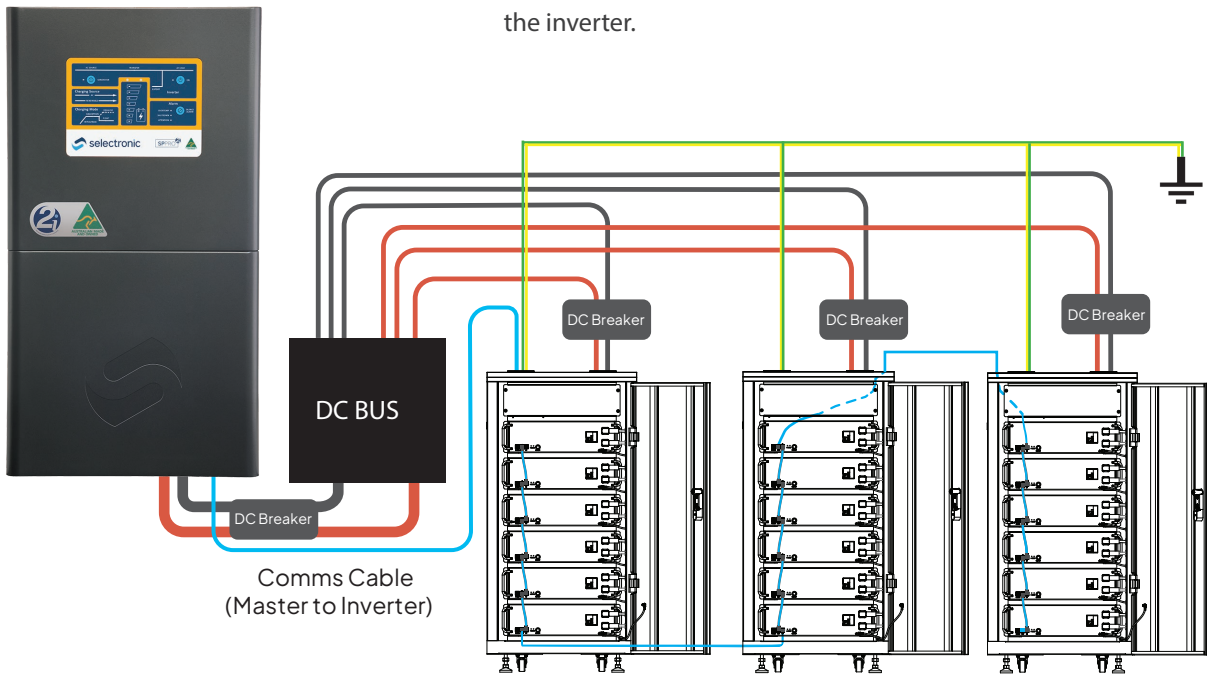

Note:

DC+ Cable

COM Cable

DC- Cable

PE Cable

Note:

1. The maximum number of paralleled LiFe² 5120S modules is 64.
2. When multiple cabinets are connected in parallel, a DC bus or DC combiner box should be used
3. The DC power cable length of all cabinets should be the same length.
4. The communication cable length should be ≤5 m and CAT5 shielded cable or greater.

6. Commissioning

6.1. LED Status

The LiFe² 5120S has LEDs to allow clear visualization of the status of the battery. These LEDs are simple and easy to understand.

LED	Status	Description
Error	●	An error has occurred.
	●	There are no active errors.
Status	●	The battery is active and can be charged and discharged.
	●	The battery is not active.
SOC	● ● ● ●	75-100% SOC
	● ● ● ●	50-75% SOC
	● ● ● ●	25-50% SOC
	● ● ● ●	0-25% SOC
	If SOC < 5% the first LED will flash quickly (0.5s ON, then 0.5s OFF)	
If Discharging the last LED normally (1s ON, then 1s OFF)		 0.5 Hz

6.2. Circuit Breaker Protection

The LiFe² 5120S has an integrated circuit breaker. The circuit breaker plays a few key roles in protecting the battery.

- Energising and de-energising the battery output when being used as an ON/OFF switch.
- Battery protection in case of overcurrent, short circuit, overvoltage, or over-discharge.
- Battery automatic trip in case of internal BMS fault.

6.3. System Start-Up and Shut-Down Procedure

Now that the batteries are installed, you are almost ready to power up the system. Before doing so, inspect your installation by checking the following:

- Correct polarity of all battery connections.
- No damage to the cables.
- All system breakers are in the OFF position.
- Adequate airflow as per installation requirements.
- Compliance with local installation regulations.

Starting up the battery system should follow the recommendations of the PCE manufacturer, this manual, and any relevant local or government safety requirements.



ON / OFF

System Start Up

- 1:** Turn ON the DC breakers between battery cabinet(s) and the Inverter.
- 2:** Turn ON the battery module breakers.
- 3:** Press and Hold the 'ON/OFF' button on Master Battery for 3 Seconds to power up the system.
- 4:** Turn ON System PV Isolators (if any).
- 5:** Turn ON System AC Isolators (if any).

System Shutdown

- 1:** Turn OFF System AC Isolators (if any).
- 2:** Turn OFF System PV Isolators (if any).
- 3:** Press and Hold the ON/OFF buttons for 3 seconds on the Master Battery for 3 seconds to power down the system
- 4:** Turn OFF the battery module breakers.
- 5:** Turn OFF the DC breakers between battery cabinet(s) and the inverter.

6.4. Charging and Discharging

The LiFe² 5120S features advanced LFP technology, enabling discharge up to -20°C and charging up to -10°C.

- Charging temperature range: -10°C to 50°C
- Discharging temperature range: -20°C to 50°C

The battery provides 100A continuous current and 200A peak current for up to 5 seconds. Ensure charging current does not exceed 100A.

For optimal system health, regularly charge to 100% State of Charge (SOC):

- Self-Managed Operation: 100% SOC calibration every 14 days minimum
- Managed Operation: 100% SOC calibration every 30 days minimum

Important:

- If auto-shutdown occurs due to extended non-charging, recharge within 10 days to restore SOC.
- For extended system shutdown with no charging source, turn off the battery ON/OFF button and switch the circuit breaker to the off position.

6.4.1 Initial System Charging

The LiFe² 5120S batteries are shipped in a low state of charge (SOC) to comply with international shipping regulations.

Upon initial system power-up, it is crucial to perform a calibration charge to 100% SOC. This calibration is particularly important for self-managed applications, where the connected Power Conversion Equipment (PCE) needs to accurately learn the battery's SOC.

Ensuring a full calibration charge on first use helps establish proper SOC reporting.

6.4.2 Maintaining Accurate SOC in Self-Managed Application

State of Charge (SoC) drift occurs when the SoC calculation accumulates errors over time, typically due to component tolerances in voltage and current measurements, and the algorithms used to determine battery capacity. Most systems reset this accumulated error when reaching 100% SoC or entering a float state.

To minimize SoC drift, the battery storage system should reach float stage or 100% SoC regularly, ideally every 1 to 3 days. Strategies to address SoC drift include:

1. Size the solar array adequately to charge batteries to float or 100% even on the winter solstice.
2. Install a backup power source (grid or generator) for charging during extended bad weather or high-load events.
3. Consult the PCE manufacturer to verify the accuracy of their SoC calculation.

6.5. Setting up Remote Monitoring

Remote Monitoring is available via the AERL Cloud and a Nexus Gateway, or through third-party inverter solutions.



Visit the QR Code to learn more about connecting your battery system.

7. Maintenance

While the battery itself is maintenance-free, regular system checks are recommended:

- Clear obstructions around the battery or enclosure
- Check for water ingress or potential water hazards
- Inspect for signs of pest infestation in or around the battery system
- Remove any accumulated debris from the cabinet and surroundings
- Verify secure battery connections and inspect cables for damage
- Test the battery breaker by cycling it off and on
- Ensure all LED indicators are functioning correctly
- Examine batteries and cabinets for any signs of physical damage

8. Adding Batteries to an Existing System

Additional LiFe² 5120S batteries can be integrated into an existing installation at any time during the warranty period. Ensure all batteries are of the same type, and part number for compatibility. If uncertain, consult AERL's After Sales Support.

The advanced design of the LiFe² 5120S allows new batteries to be added regardless of State of Charge (SOC) or voltage. The system will self-balance, matching the new battery to the existing bank's SOC and voltage.

For Self-Managed mode applications, update all power conversion equipment (PCE) to reflect the increased overall battery capacity.

Note: Mixing different battery types or capacities within a rack is not supported. All batteries in a rack must be identical in type, part number, and specification, unless otherwise advised by AERL.

9. Recovering a Flat Battery

If a battery module's State of Charge (SOC) reaches 0% and voltage drops below 40V, indicating over-discharge, follow these recharging methods:

1. If operational, use the inverter to charge the battery directly.
2. Connect a higher voltage module in parallel to automatically balance and charge the depleted module.
3. When inverter charging is not possible, use a 48V adjustable constant current charger set to 54V and 10A. Charge for at least 30 minutes.

Note: For batteries that have auto-shutdown due to extended non-charging, recharge within 10 days to restore a healthy SOC.

10. Battery End of Life and Recycling

The LiFe² 5120S battery is designed for long-lasting performance. When it's time for replacement, AERL offers a responsible end-of-life solution:

1. Return the battery to AERL for assessment.
2. Suitable batteries are tested and refurbished for:
 - Charitable organizations / Community projects / Educational applications
3. Non-refurbishable batteries are recycled to:
 - Maximize material recovery / Support the circular economy / Minimize environmental impact

By choosing LiFe² 5120S, you're investing in advanced energy storage and contributing to a sustainable future. This approach extends battery life cycles and ensures responsible disposal, aligning with AERL's commitment to environmental stewardship.

11. Battery Cycle Performance Characteristics

80% DOD Cycling Curve At Different Temperatures

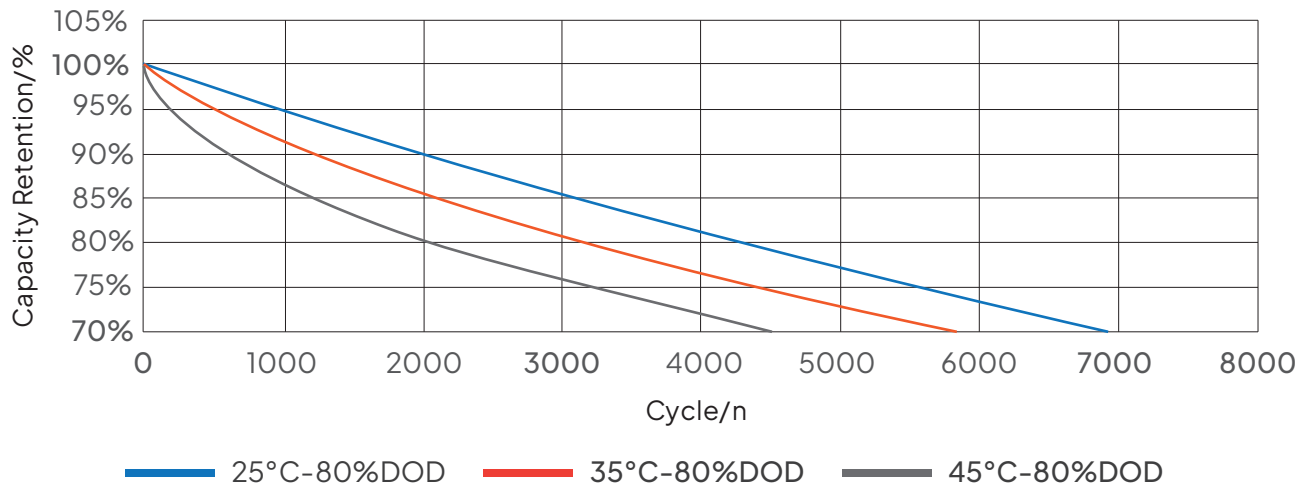

90% DOD Cycling Curve At Different Temperatures

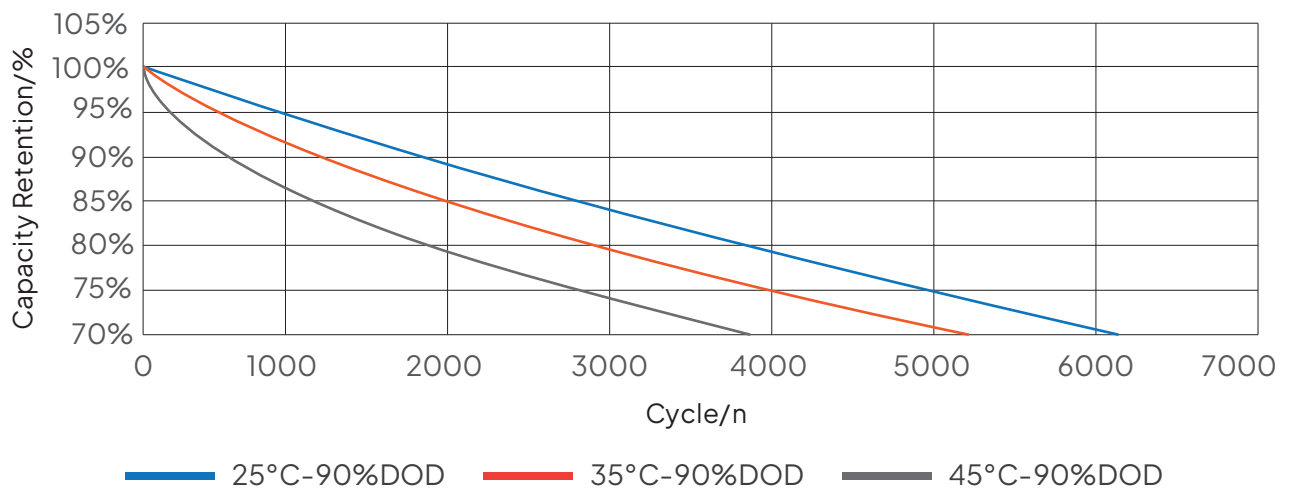

100% DOD Cycling Curve At Different Temperatures

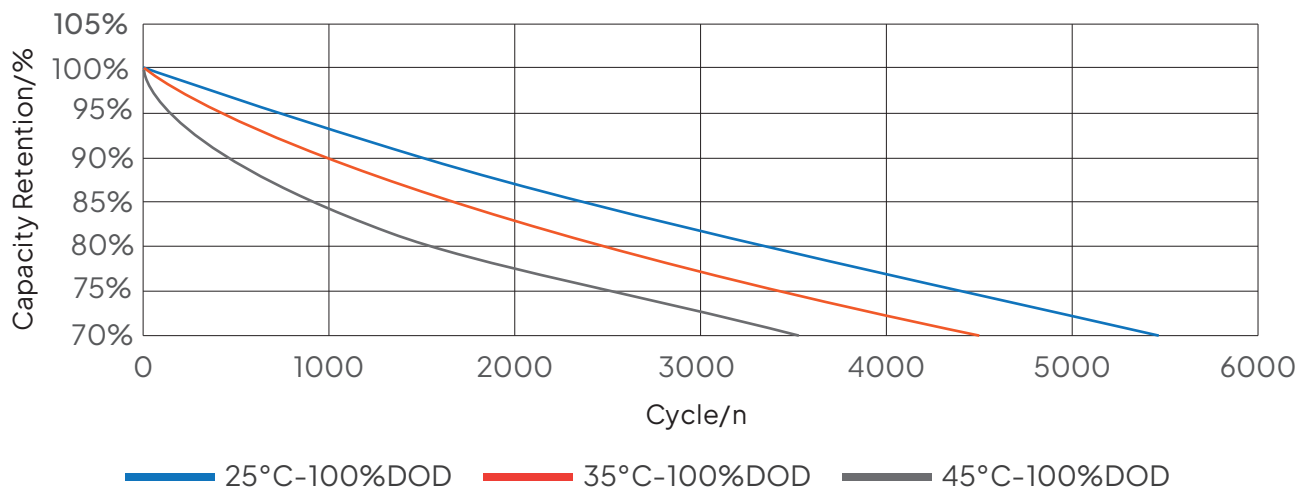

12. Managed Battery Performance, Charge and Discharge

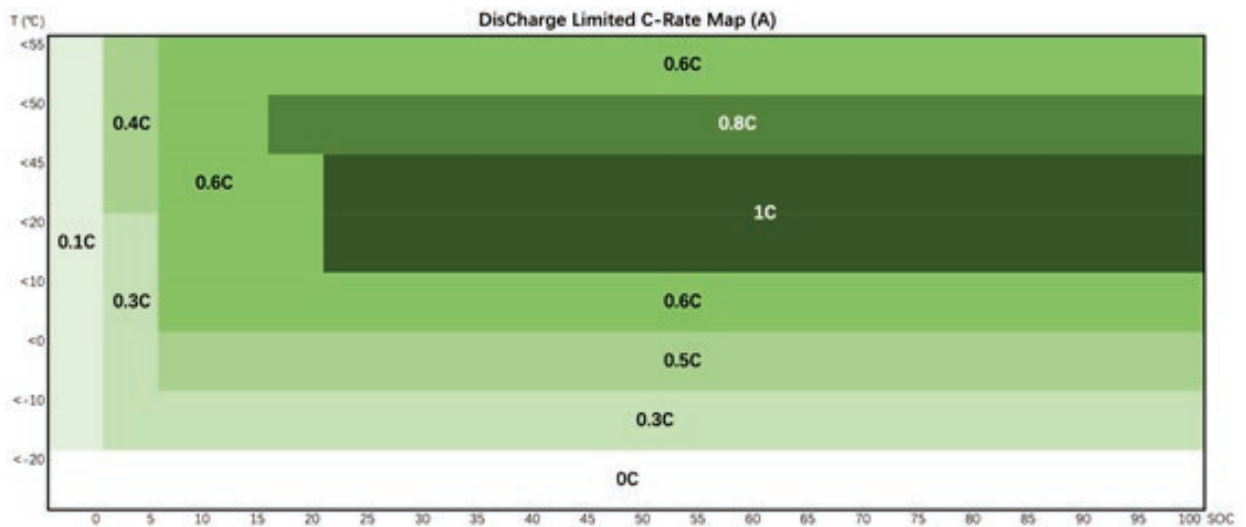
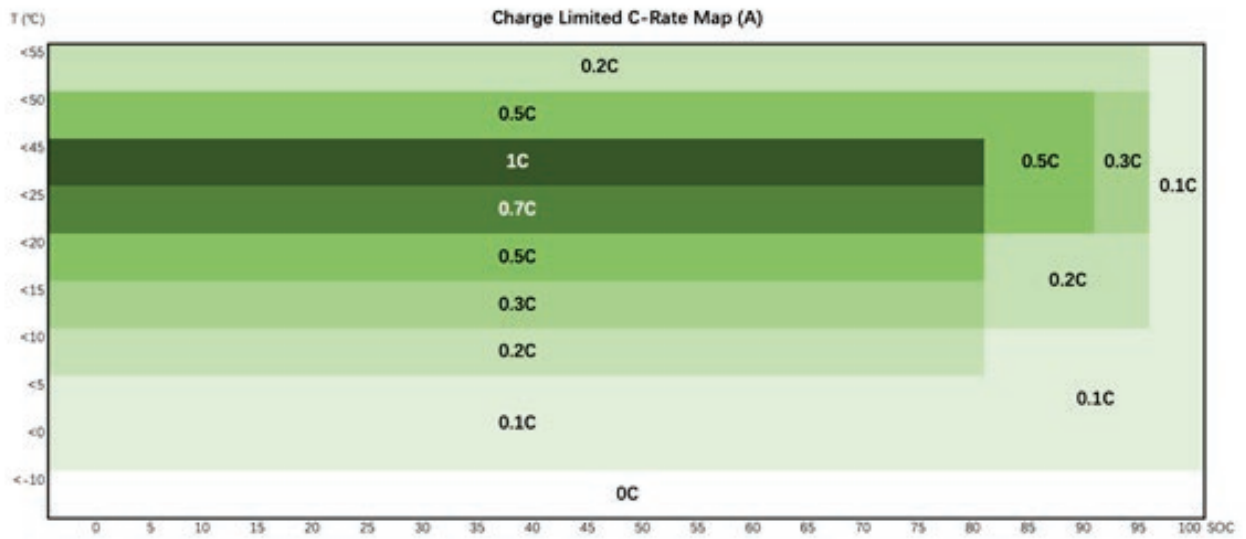

Thank you for choosing AERL.

Your decision to trust our product means a lot to us.

At AERL, our focus is on technical excellence. Our batteries are the result of rigorous engineering and precise craftsmanship, and we have invested heavily in ensuring that each battery delivers outstanding performance and reliability.

We recognize the importance of dependable power in standalone applications, and we are committed to providing you with top-tier products that get the job done.

If you have any questions or need support,
our team is always ready to assist.

Sincerely,

The AERL Team

The logo for AERL, featuring the lowercase letters 'aerl' in a stylized, orange, sans-serif font.

1/75 Bluestone Circuit, Seventeen Mile Rocks, QLD
+611800 950 865 | support@aerl.com.au

www.aerl.com.au