



RACEMAX MAXIMIZER™

Installation and Operation Manual

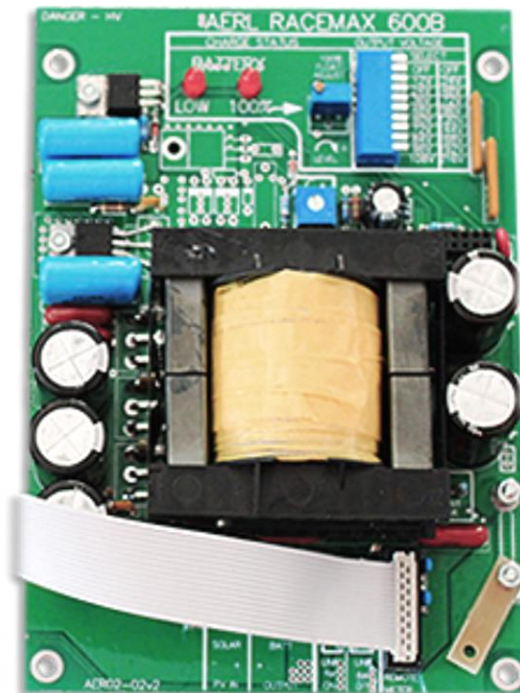



TABLE OF CONTENTS

Section Number	Topic	Page Number
1	Warranty	3
2	Specifications	4
3	Overview	4
4	PCB Layout	5
5	Safety Information	5
6	Circuit Breakers	6
7	Installation	7
7.1	Mounting	7
7.2	Connections	8
8	Operating Guidelines	8
8.1	Powering up the unit	9
8.2	100% battery float voltage adjustment	9
8.3	Peak power tracking setup	10
9	Connecting Optional Meter Module	11
10	Troubleshooting	12
10.1	Low battery light often comes on	12
10.2	Unit does not charge the battery	12
10.3	Battery bank using excessive water (Electrolyte)	13
10.4	Unit does not boost voltage	13

Important Safety Information

This Installation Manual contains important safety information and Installation instructions for the RACEMAX 600B MAXIMIZER™.

The following symbols are used throughout this user manual to indicate ideal Installation methods, to indicate potential dangerous conditions and important operational information.

**Important**

Indicates information that must be followed to ensure proper operation of the COOLMAX SR unit.

**CAUTION**

Indicates a critical procedure for the safe Installation of the COOLMAX SR unit. Use extreme caution when performing this task.

About this Manual

**Important**

- This User Manual provides detailed installation and usage instructions for the RACEMAX 600B MAXIMIZER™ unit. It is recommended that all of the Instructions and Cautions in this User Manual be read before beginning installation.
- Only qualified electricians and technicians should install the RACEMAX 600B MAXIMIZER™ unit. This manual is intended for all Installation technicians and the system owner.
- Do not disassemble or attempt to repair the RACEMAX 600B MAXIMIZER™ unit unless you are a qualified technician and have authority in writing from AERL to do so.
- AERL will not be held responsible in any way for the mishandling of this product or for installation of the product in a manner that does not follow the instructions in this manual or as advised by an AERL technician.

1. WARRANTY

2. AERL warrants that the Product will be free from manufacturing defects for a period of 24 months from the date of dispatch of the products by AERL to the customer.
3. The Products technical specifications are contained within the Product Datasheet. The Product will conform to the technical specifications contained in the Product Datasheet at the time of dispatch of the Products to the Customer. If the technical specifications as contained in the Product Datasheet are not met, AERL will repair, replace the Product, or refund the amount paid by the Customer in relation to the Product at the Customers option. AERL is under no obligation to provide assistance or advice to the Customer in relation to the technical specifications. The Products must be installed in strict accordance with the Installation Recommendations listed in this Manual.
4. In no event will AERL be liable for:
 - a) any loss or damage which the Customer suffers arising from, or caused or contributed to by, the Customer's negligence or the negligence of the Customer's agents or servants; and
 - b) special, indirect or consequential loss or damage as a result of a breach by the Customer of these Standard Terms including, without limitation, loss of profits or revenue, personal injury, death, property damage and the costs of any substitute Products which the Customer obtains.
5. The Product is not covered for damage occurring due to water, including but not limited to condensation, moisture damage and other forms of precipitation.
6. The Product is not covered for damage occurring due to the Product being incorrectly installed or installed in a manner not in accordance with the Installation Recommendations listed in the Product Manual.
7. The Product is not covered for damage occurring due to failure on the part of the customer to operate the product in accordance with the technical specifications as listed in the Product Datasheet.
8. The Product is not covered for damage occurring due to lightning.
9. The Product is not covered for situations where it is used in a manner not specifically outlined in the Product Manual.
10. If any provision in this document is invalid or unenforceable this document will remain otherwise in full force apart from such provision, which will be deemed deleted.

Disclaimer:

Australian Energy Research Laboratories Pty Ltd, its affiliates, agents, and employees, and all persons acting on its or their behalf (collectively, "AERL"):

- a) Disclaim any and all liability for any errors, inaccuracies or incompleteness contained in any datasheet or in any other disclosure relating to any product
- b) Assumes no responsibility or liability for loss or damage whether direct, indirect, consequential or incidental, which might arise out of use of such information. The use of any such information will be entirely at the user's risk.
- c) Reserves the right to change any AERL product, product specifications and data without notice to improve reliability, function or design or otherwise.

Notice of Copyright

AERL RACEMAX 600B MAXIMIZER™ User Manual Copyright © 2016 all rights reserved. AERL reserves the right to revise this document and to periodically make changes to the content.

2 SPECIFICATIONS

Performance Data

Symbol	Parameter	Max
T_{amb}	Maximum ambient air temperature	50°C
$I_{sc-const}$	PV panel short circuit current - constant	6A
$I_{sc-trans}$	PV panel short circuit current – transient	8A

Electrical Characteristics

Symbol	Parameter	Min	Max
P_{mp}	Solar panel peak power	0W	600W
V_{oc}	PV panel open circuit voltage	40V	135V
η	Efficiency @ 6A, 100Vmp (144Vbatt), & 25°Camb	97.60%	-
V_{Batt}	Battery Voltage (Selectable)	48-144V	

Physical Characteristics

Parameter	Typical
Weight	720g
Dimensions (L x W x H)	170 x 120 x 65 mm

3 OVERVIEW

The AERL RACEMAX 600B MAXIMIZER™ is a high efficiency, boost only, common negative peak power point tracker. It employs a tracking strategy which regulates the PV array voltage to a fixed percentage of its open circuit voltage. This tracking strategy has been proven to be highly robust, immune to local extrema, and results in power losses of less than 0.5% over the whole operating temperature range of a PV array.

The improved power of the new RACEMAX over previous models makes it an ideal choice for solar car teams looking to get the most out of their PV array.

Some of the device's main features include:

- High 98 – 99% peak operating efficiency.
- Compatible with all types of solar cells and battery arrays.
- Passive cooling & no moving parts results in highly reliable operation to 50°C.
- Output voltage options of 48 - 144V.
- Compact and lightweight design, weighing only 750g.

4 PCB LAYOUT

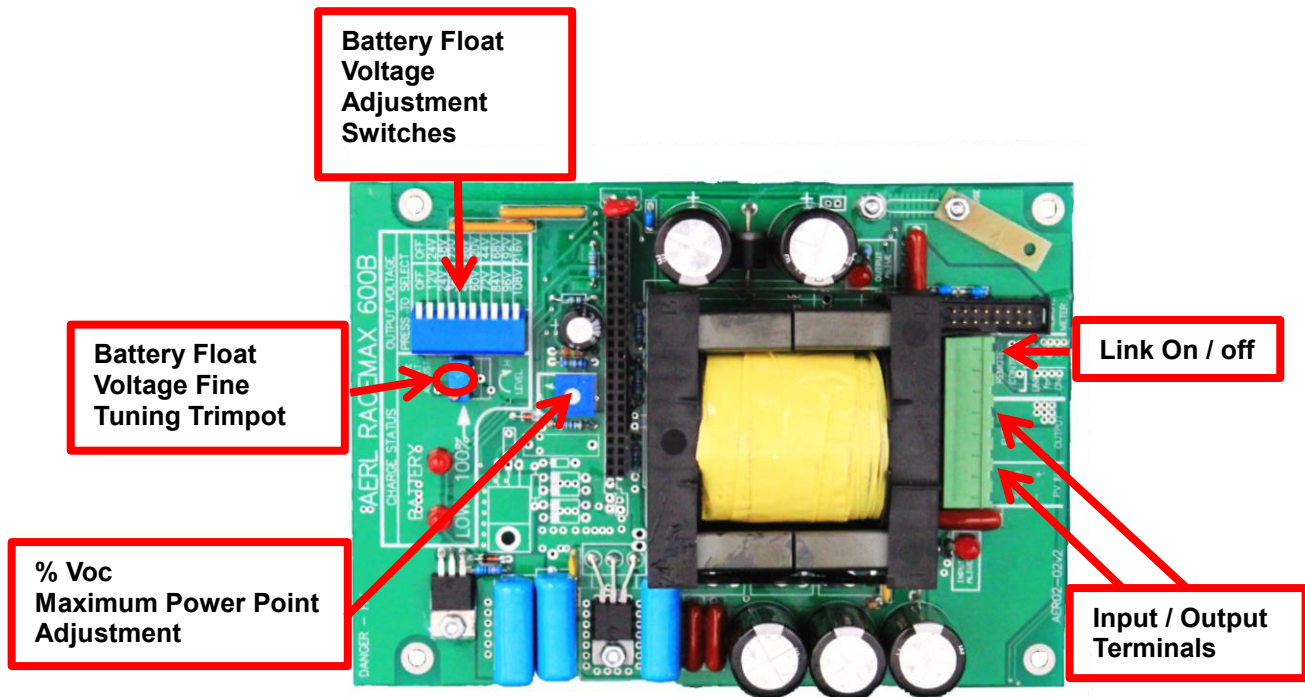

Figure 1: RACEMAX 600B Layout

5 SAFETY INFORMATION



CAUTION

- The DC voltage at which the RACEMAX MAXIMIZER™ unit operates can be potentially lethal if handled without adequate caution.
- Never touch the RACEMAX MAXIMIZER™ unit at any time while it is on. Some adjustments can only be made to the unit while it is operating. Ensure that these are done with an electrically isolated tool and that caution is used at all times.
- The “LINK ON / OFF” control input does not isolate the inputs or outputs of the RACEMAX unit, it simply generates a reset signal that disables the RACEMAX. The circuitry on the RACEMAX board will continue to float at Battery Voltage and / or PV Voltage even with the OFF switch depressed.
- Do not exceed the Current and Voltage ratings marked on every RACEMAX and listed in the datasheet. To do so would immediately void the warranty.
- The PV Input Open-Circuit Voltage and Current rating must not be exceeded.
- Always ensure that the RACEMAX Off switch on the Piano switch is depressed before making or breaking any connections.

- Always measure the PV Open-Circuit Voltage and Polarity and Battery Polarity before closing the circuit-breakers and making the final connection to the RACEMAX.
- To avoid exceeding the maximum short circuit current listed in the datasheet, care should be taken that the total power rating of the PV Array does not exceed the battery voltage multiplied by the maximum short circuit current.

6 CIRCUIT BREAKERS



CAUTION: AERL recommends the use of DC rated input and output protection circuit breakers with appropriate voltage and current ratings.

The RACEMAX unit does have an on-board diode for the RACEMAX boost conversion which will also act as a blocking diode to prevent backflow of current from the batteries back to the PV Panels. This diode will also prevent backflow of current into RACEMAX units when they are paralleled at the Battery side. However, AERL recommends also using suitable DC rated input and output circuit breakers to protect the RACEMAX unit from all other dangers eg. Incorrect wiring, over voltage, over current etc.

0 -120V OUTPUT

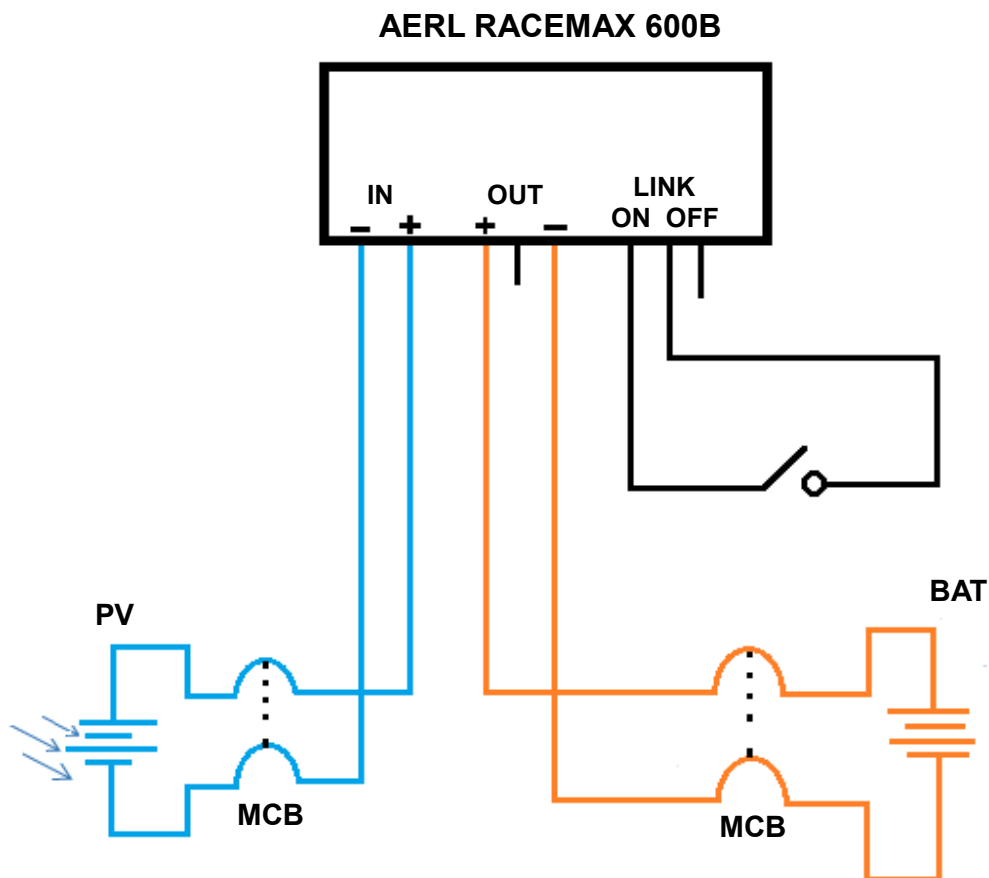

Figure 2: RACEMAX circuit breaker configuration using 60V, 20A 6kA MCBs for different output voltages.

120 – 180V OUTPUT

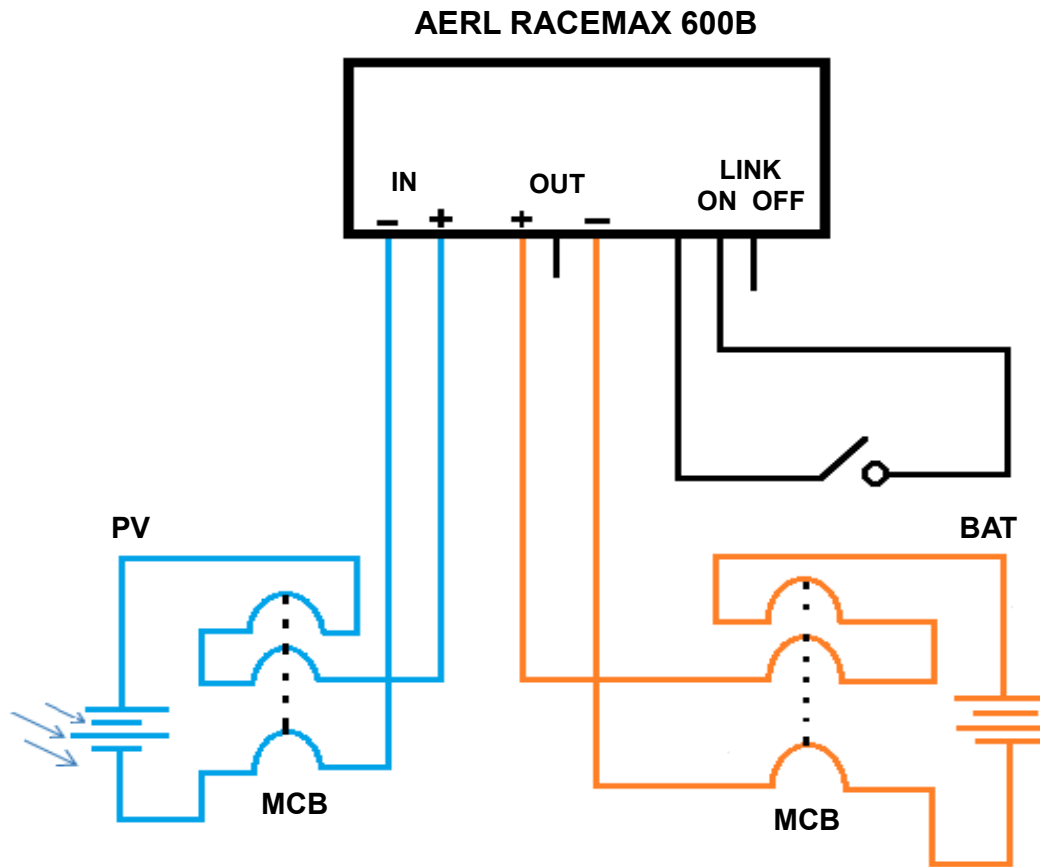

Figure 2.1: RACEMAX circuit breaker configuration using 60V, 20A 6kA MCBs for different output voltages.



Important: Lower current rated circuit breakers can be used, however, AERL does not recommend using anything lower than a 10A circuit breaker. The RACEMAX unit can handle up to at least a 8A temporary surge without damage.

7 INSTALLATION

7.1 MOUNTING



Important

- Do not mount the unit where rain or direct sunlight can reach the unit, or where moisture condensation can affect the unit.
- Do not mount the unit anywhere that airflow is restricted.
- Never mount the unit in a sealed enclosure as it will overheat.

- If the RACEMAX is to be mounted in an enclosure, ensure that the cabinet is large and adequately ventilated.
- Power transfer efficiency of the RACEMAX unit will be better the cooler the unit is kept.

7.2 CONNECTIONS



CAUTION

- Ensure that the RACEMAX is switched OFF by unlinking terminals 6 & 7 on the main connector.
- Use appropriately rated wire to connect PV input and battery bank output. AERL recommends using AWG 16 or 17 Gauge wire capable of 8A current capacity for your wiring.
- Polarity is indicated on the board. Reversing polarity of input or output will cause damage to the RACEMAX and void product warranty.
- RACEMAX units can be paralleled at the output (battery side). However, NEVER wire units in parallel on the input side (only one PV array string can be wired into one RACEMAX unit) and NEVER parallel up any other type of charge controllers with the RACEMAX unit.
- If all RACEMAX units are wired in parallel on the output, ensure each unit is setup for the same charge voltage setting trimmed to be operating at the same "float voltage" via the DIP switches and trimpots.
- Install circuit breakers as shown in Section 4 (See Fig: 2, 2.1). If MPPTs are wired in parallel on the output, one circuit breaker is still required per MPPT on the output side. Using only a single higher rated Circuit Breaker on the output may still allow damaging currents to pass through an individual RACEMAX Unit and exceed its rating.
- Check the polarity of the input and output with a multimeter before switching on the RACEMAX.
- Terminals 6 & 7 ("Link ON") need to be linked to switch the RACEMAX on. It can be useful to wire a switch in between terminals 6 & 7 to allow the RACEMAX control to be disabled when necessary. Note that switching the RACEMAX off by disconnecting terminals 6 & 7 does not make the RACEMAX safe to touch.

8 OPERATING GUIDELINES



Important

- Terminals 6 & 7 are not linked on the main input connector, before making any electrical connections or closing any Input and Output Circuit-Breakers ensure that the RACEMAX is switched off.
- To avoid overloading the RACEMAX, pay attention to the warnings given in Section 5.
- It is important to avoid connecting the RACEMAX to a PV Array if its power rating exceeds the battery

bank voltage multiplied by the maximum short circuit current quoted on the RACEMAX datasheet. To do so will overload the current handling capabilities of the product, most likely causing damage to the board and void product warranty.

8.1 POWERING UP THE RACEMAX UNIT



Important

- The RACEMAX unit must have a link placed between terminals 6 & 7 on the main input connector, where it is marked 'Link for ON' for the control to be enabled.
- It is highly recommended that the RACEMAX be connected to the load at all times when it is enabled. Avoid switching the RACEMAX on with the battery disconnected (i.e. battery circuit breaker open) or disconnecting the battery while the RACEMAX is switched ON.

8.2 100% BATTERY FLOAT VOLTAGE ADJUSTMENT

When connected to a battery pack, the RACEMAX unit is designed to charge to a preset voltage point and then maintain constant voltage. The 100% float set point can be adjusted using a combination of the piano dipswitches to set the appropriate range and the float adjustment trimpot for fine tuning (See Fig.1).

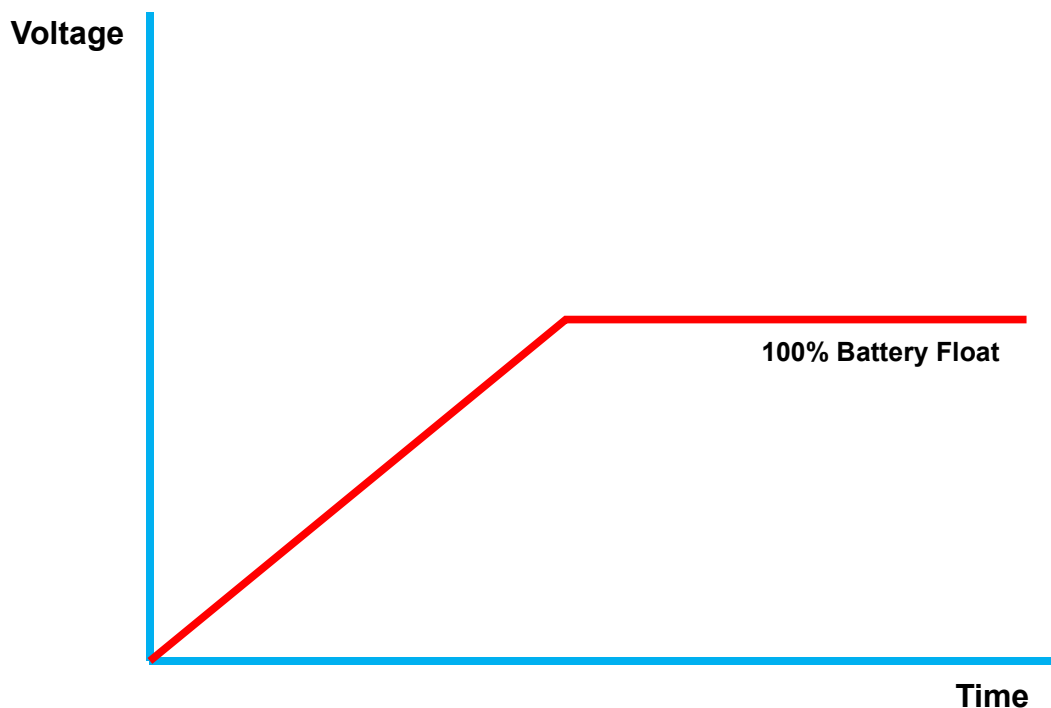

Figure 3: Charging Profile of the RACEMAX MAXIMIZER™

If the battery voltage is above the 100% float set point, the 100% full LED will be on. If the battery voltage is below the 100% float set point, the LED will switch off. This can be used as feedback to



indicate the position of the 100% float set point, if the RACEMAX MAXIMIZER™ is connected to a known voltage.

Note: The 100% full LED will work as an indicator of the 100% float set point even if the Maximizer is disabled.

Adjustment Procedure

- Connect the battery pack to output of the RACEMAX.
- When the battery pack is at the desired top of charge voltage, adjust the piano dipswitch voltage and the trimpot so that the 100% full LED only just turns on.

The following table (**Fig.4**) shows roughly the range of values that can be set with the piano dipswitch and the trimpot on the RACEMAX. The output voltage can be adjusted between its minimum and maximum range using the float adjust trimpot.

HV MODE (DEFAULT)

SWITCH	For Use with Nominal Battery Voltage	MIN INPUT VOLT	MIN OUTPUT VOLT	MAX OUTPUT VOLT
12/24	N/A	Not Supported in this Model - DO NOT USE THIS SETTING		
24/48	48	40	51	60
36/72	72	50	77	90
48/96	96	60	103	120
60/120	120	80	128	150
72/144	144	90	153	180
84/168	N/A	Not Supported in this Model - DO NOT USE THIS SETTING		
96/182	N/A	Not Supported in this Model - DO NOT USE THIS SETTING		
108/216	N/A	Not Supported in this Model - DO NOT USE THIS SETTING		

Figure 4: RACEMAX MAXIMIZER™ Settings and Operating Ranges

8.3 PEAK POWER TRACKING SETUP

During normal operation, the RACEMAX tracks the peak power point of the PV array by periodically sampling the open-circuit voltage of the array. It then sets the array voltage to a percentage (usually between 70 – 85%) of the measured Voc.

Note: Due to the periodic sampling operation, the RACEMAX unit is disabled to measure Voc for about 0.066% of its running time.

Adjusting the Voc Percentage (% Voc)

The Voc Percentage can be adjusted using the following steps:

With the batteries and the array isolated, connect an ammeter in series between the battery bank and the RACEMAX.

Locate VR2, the trimpot just above the header for the control board (See Fig.1).

Switch the RACEMAX on, close the battery and PV array circuit breakers and measure the current flowing into the batteries.

 **Important**

The batteries will need to be discharged below the 100% battery float level and the battery 100% light should not be on during this process.

Using a plastic screw driver, sweep the VR2 trimpot through the range to achieve the maximum current transfer into the batteries. This will set the voltage at the peak power point for the PV array. Always use caution when making adjustments to the RACEMAX while it is connected to the PV array or the battery pack.

9 CONNECTING THE OPTIONAL METER MODULE

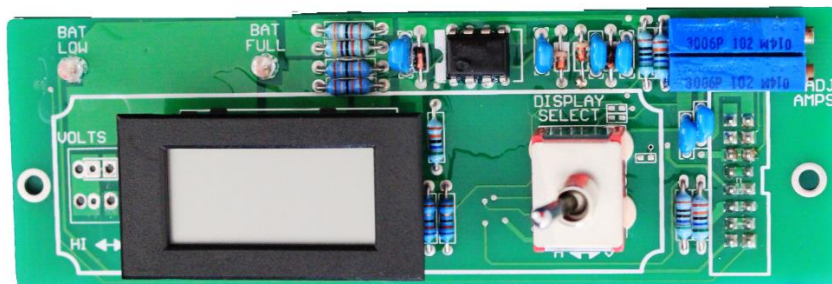

Figure 5: Front View of Meter Module

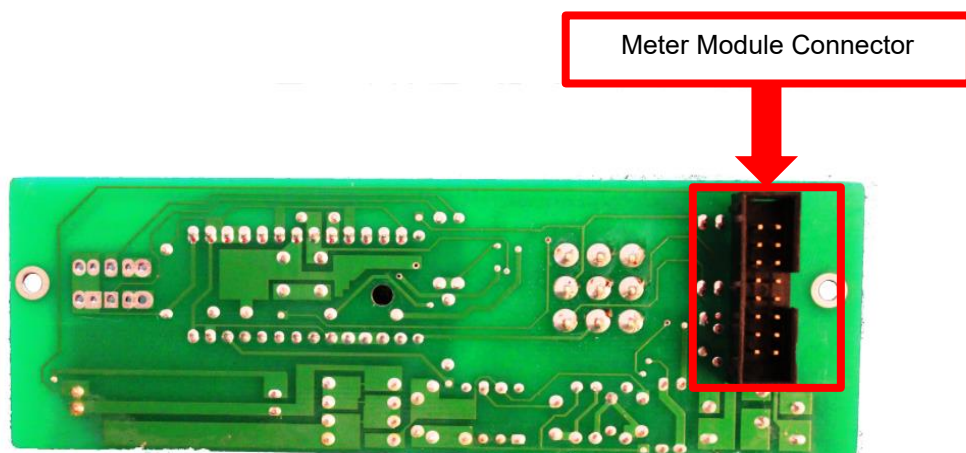

Figure 5A: Rear View of Meter Module

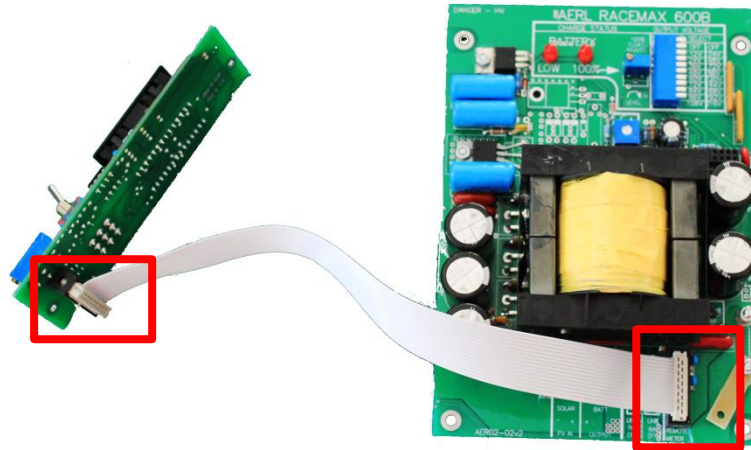

Figure 5B: Meter Module connected to the RACEMAX MAXIMIZER™ with a Ribbon Cable

10 TROUBLESHOOTING

10.1 LOW BATTERY LIGHT OFTEN COMES ON

This could indicate that the PV system is underpowered, never reaching a full 108% equalise value. The battery life will be severely compromised in this situation. The more often the LED comes on, the more power should be added to the PV array.

Solution: Add more PV modules to the array to increase the power output.

If the array is sufficiently powerful, but the LED is still very often on, check that the RACEMAX is set up for the correct voltage of the battery pack. See section 8.2 for adjusting the battery float voltage. Also check that the RACEMAX is charging the battery by checking the output current on the LCD meter, and if the RACEMAX is not functioning continue to 10.2.

10.2 UNIT DOES NOT CHARGE THE BATTERY

If Temperature Compensation is not being used (default setup) ensure that the switch marked Temp. Comp. OFF (switch number 9) is pressed down. Not doing so may cause the unit to behave strangely. If this does not resolve the issue check the following:

- All connections to the RACEMAX are secure and screw terminals are done up tight.
- Check that the RACEMAX is enabled using a link between terminals 6 & 7 (**Link ON**)
- Check the integrity of the blue circular MOVs. These are surge protectors and will fail destructively in the event of circuit overload. This could indicate a fault with the unit and it should be returned for repair.
- Check the integrity of the large crowbar diodes located below the main inductor winding. These fail destructively if a reverse polarity is applied.
- Check with a multimeter that the input voltage is sufficient to power the Maximizer. If the input voltage is below the minimum input voltage of the RACEMAX the unit will not power up.

**Important**

The minimum input voltage of the RACEMAX changes depending on the nominal voltage of the battery pack in use. The rule of thumb is $V_{oc} > 1.65 \times V_{nom}$. Check the datasheet for a graph to show the minimum input voltage depending on battery pack voltage.

10.3 BATTERY BANK USING EXCESSIVE WATER (ELECTROLYTE)

The battery bank is lightly loaded compared to the input PV power and rarely comes off FLOAT voltage.

Solution: Press the 5th Piano Dipswitch marked “Sealed Batts” to drop the FLOAT voltage by 2.5%.

10.4 MAXIMIZER DOES NOT BOOST VOLTAGE

Solution: Check that the RACEMAX is enabled using a link between terminals 6 & 7 (**Link ON**)